

REVISIONS				
REV.	DESCRIPTION	D.C.P.	DATE	DRAWN BY
1	FOR DISTRIBUTION	MOC 60	01/06/21	GMASON

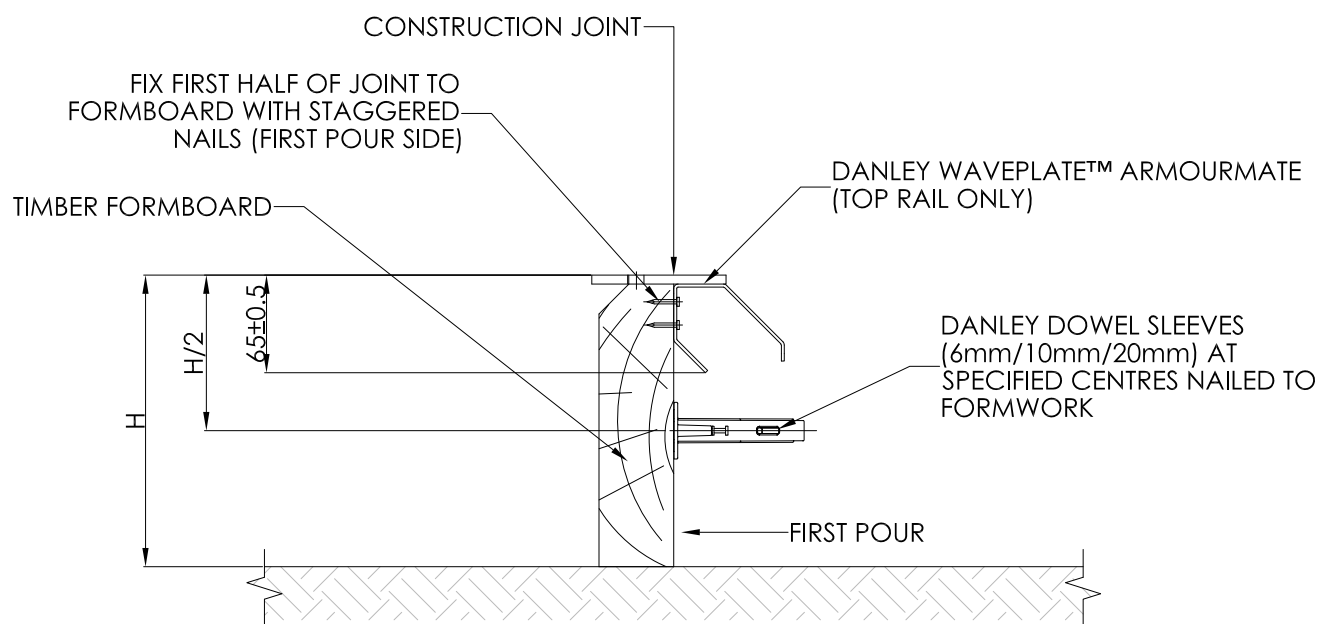

STEP 1 - ARMoured DOWEL JOINT (A.D.J.)
SCALE: 1:5

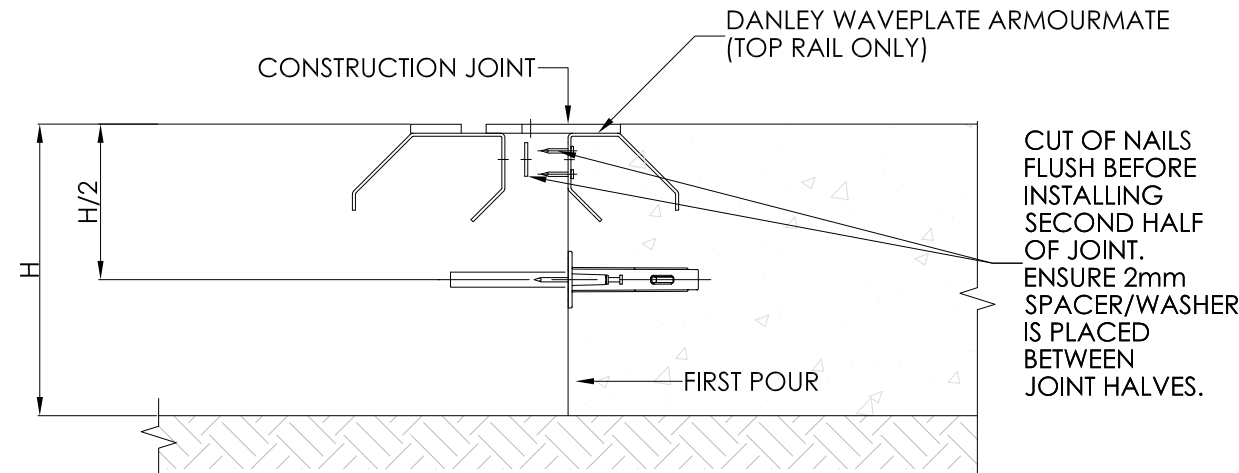

STEP 2 - ARMoured DOWEL JOINT (A.D.J.)
SCALE: 1:5

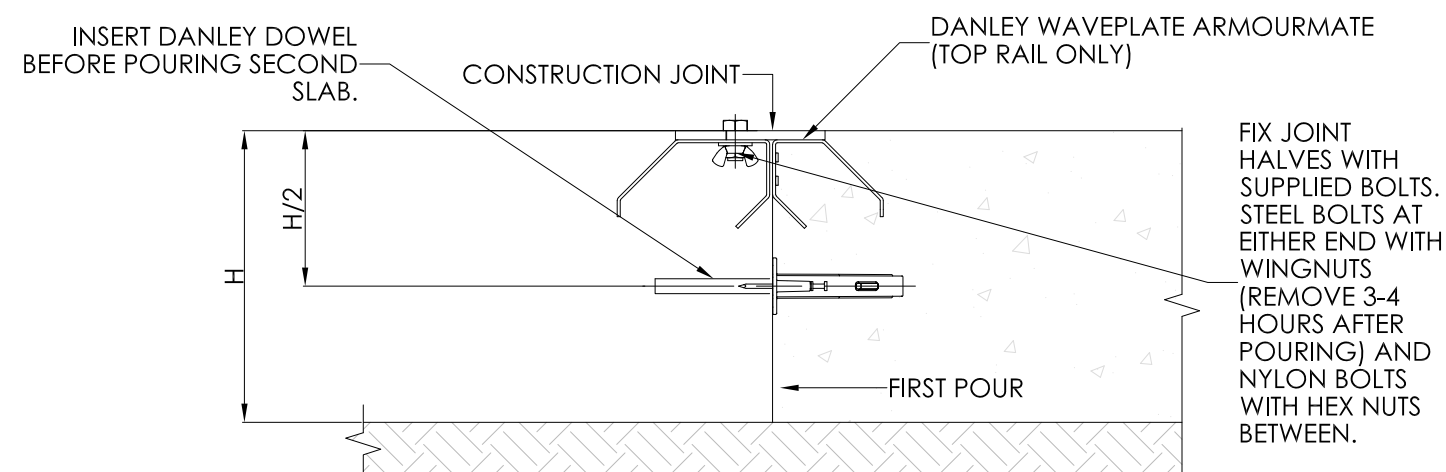

STEP 3 - ARMoured DOWEL JOINT (A.D.J.)
SCALE: 1:5

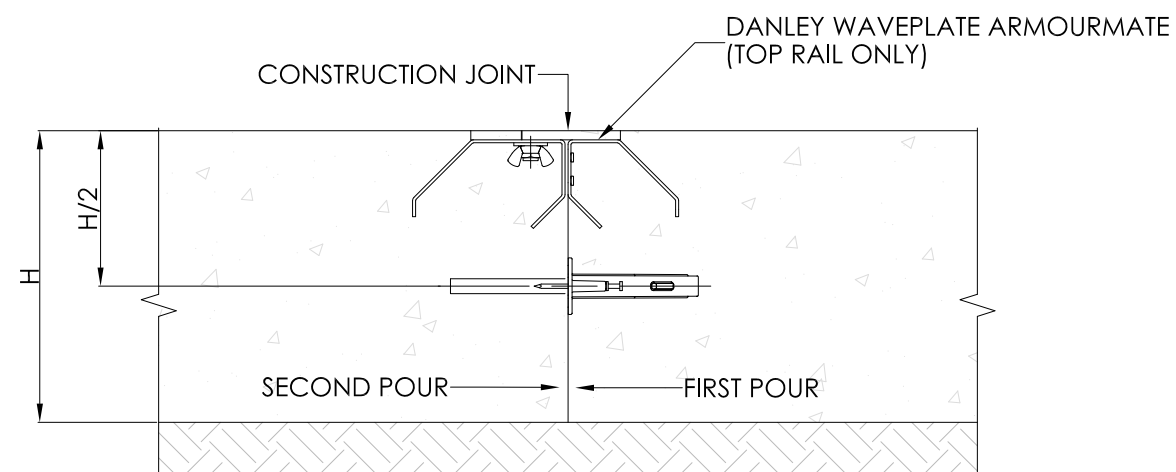

STEP 4 - ARMoured DOWEL JOINT (A.D.J.)
SCALE: 1:5

GENERAL NOTES:

WAVEPLATE™ ARMOURMATE™ DANLEY™ WAVEPLATE™ ARMOURMATE™ (TOP RAIL ONLY) WITH DISRUPTED JOINT TECHNOLOGY CREATES A FULLY SUPPORTED, SMOOTH TRANSITION FOR MATERIAL HANDLING EQUIPMENT (MHE) ACROSS JOINT WIDTH. RECOMMENDED FOR USE WITH DANLEY™ DOWELS (SUPPLIED SEPARATELY) THAT PROVIDE LOAD TRANSFER ACROSS THE JOINT. OTHER LOAD TRANSFER SYSTEMS POSSIBLE FOR USE WITH ENGINEERS SPECIFICATION. DANLEY™ DOWELS ARE AVAILABLE IN BLACK, GALVANISED OR STAINLESS STEEL.

<p>1 WHEATSTONE PLACE, SOUTHFIELD INDUSTRIAL ESTATE, GLENROTHES, KY6 2SW A DIVISION OF ITW CONSTRUCTION PRODUCTS</p> <p>TEL: +44 800 833381 EML: info@danley.co.uk WEB: www.danley.co.uk</p>	<p>THE INFORMATION CONTAINED IN THIS DRAWING IS THE SOLE PROPERTY OF ITW CONSTRUCTION PRODUCTS.</p> <p>DO NOT SCALE THIS DRAWING.</p>	DESCRIPTION: WAVEPLATE™ ARMOURMATE™ SECTIONAL VIEWS - TOP RAIL		
		SIGNED: GMASON	VERIFIED: KRICHTER	APPROVED: DMANTLE
		DATE: 01/06/21	04/06/21	08/06/21
		CAD FILE: DAN-DWG-029 - WavePlate™ ArmourMate™ Sectional Views (Top Rail Only) (UK Version)		
DRAWING NO: DAN-DWG-029		SCALE: 1:5	REVISION: 1	
SHEET: 1 OF 5		SIZE: A3		