

REVISIONS				
REV.	DESCRIPTION	D.C.P.	DATE	DRAWN BY
1	FOR DISTRIBUTION	MOC 60	01/06/21	GMASON

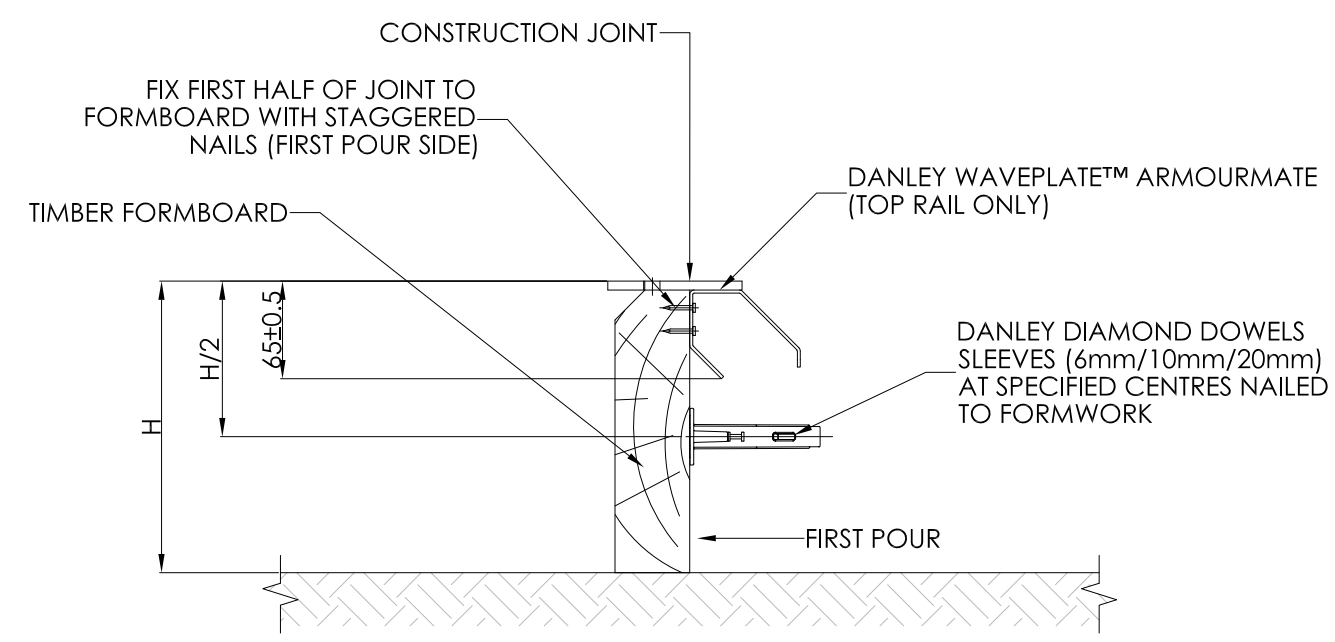

**STEP 1 - ARMoured DOWEL JOINT (A.D.J.)**  
SCALE: 1:5

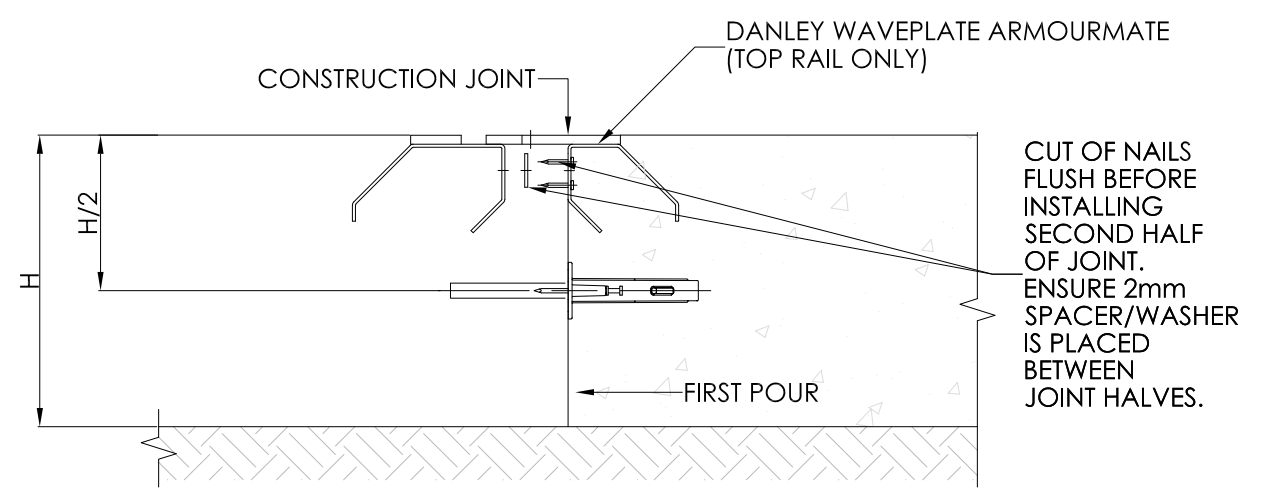

**STEP 2 - ARMoured DOWEL JOINT (A.D.J.)**  
SCALE: 1:5

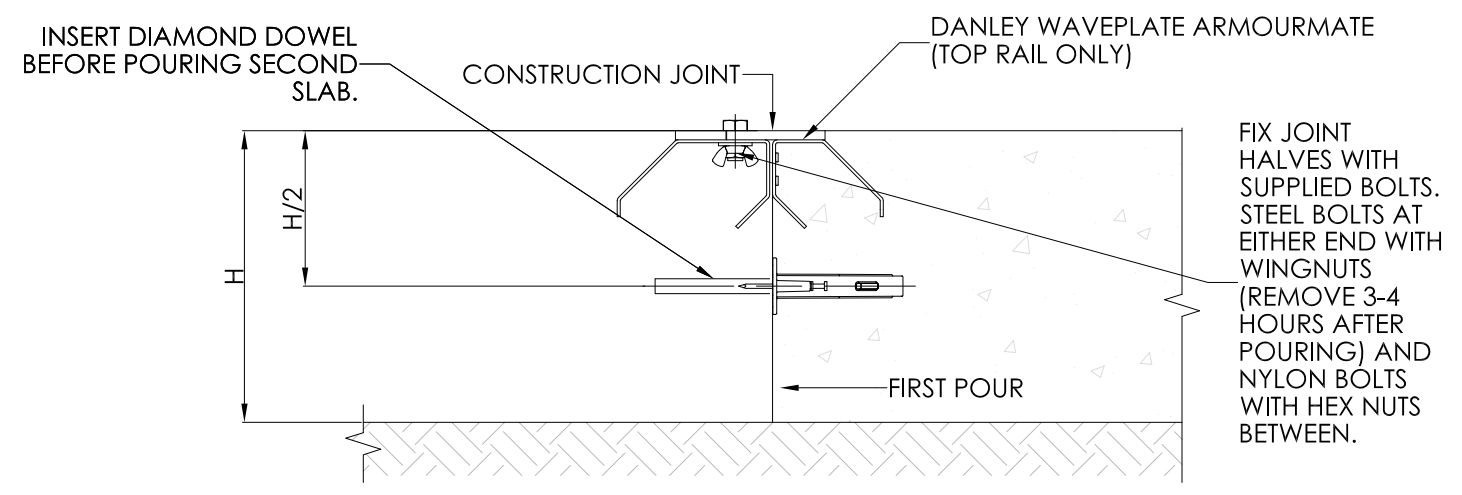

**STEP 3 - ARMoured DOWEL JOINT (A.D.J.)**  
SCALE: 1:5

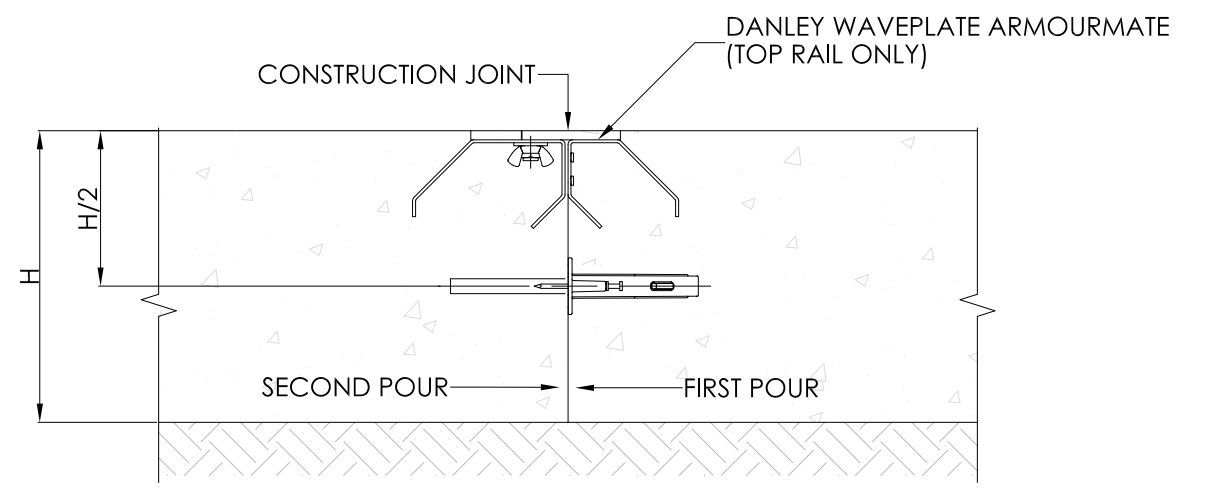

**STEP 4 - ARMoured DOWEL JOINT (A.D.J.)**  
SCALE: 1:5

**GENERAL NOTES:**

**WAVEPLATE™ ARMOURMATE™** DANLEY™ WAVEPLATE™ ARMOURMATE™ (TOP RAIL ONLY) WITH DISRUPTED JOINT TECHNOLOGY CREATES A FULLY SUPPORTED, SMOOTH TRANSITION FOR MATERIAL HANDLING EQUIPMENT (MHE) ACROSS JOINT WIDTH. RECOMMENDED FOR USE WITH DANLEY™ DIAMOND™ DOWELS (SUPPLIED SEPARATELY) THAT PROVIDE LOAD TRANSFER ACROSS THE JOINT. OTHER LOAD TRANSFER SYSTEMS POSSIBLE FOR USE WITH ENGINEERS SPECIFICATION. DANLEY™ DIAMOND™ DOWELS ARE AVAILABLE IN BLACK, GALVANISED OR STAINLESS STEEL.

**reid™**  
Construction Systems

**DANLEY™**

21 STEEL PLACE, MORNINGSID, QLD, 4170.  
A DIVISION OF ITW AUSTRALIA PTY. LTD.

TEL: 1300 DANLEY (1300 326 539) FAX: (07) 3899 1733  
EML:sales@danley.com.au  
WEB: www.danley.com.au

DESCRIPTION: WAVEPLATE™ ARMOURMATE™ SECTIONAL VIEWS - TOP RAIL			
SIGNED:	DRAWN: GMASON	VERIFIED: KRICHTER	APPROVED: DMANTLE
DATE:	01/06/21	04/06/21	08/06/21
CAD FILE: DAN-DWG-022 - WavePlate™ ArmourMate™ Sectional Views (Top Rail Only)			
DRAWING NO: <b>DAN-DWG-022</b>			SCALE: 1:5
SHEET: 1 OF 5		SIZE: A3	REVISION: 1

DO NOT SCALE THIS DRAWING.