

REVISIONS				
REV.	DESCRIPTION	D.C.P.	DATE	DRAWN BY
1	FOR DISTRIBUTION	-	09/04/20	GMASON
2	SLEEVE DESIGNS CHANGED.	NGDD	03/04/23	GMASON

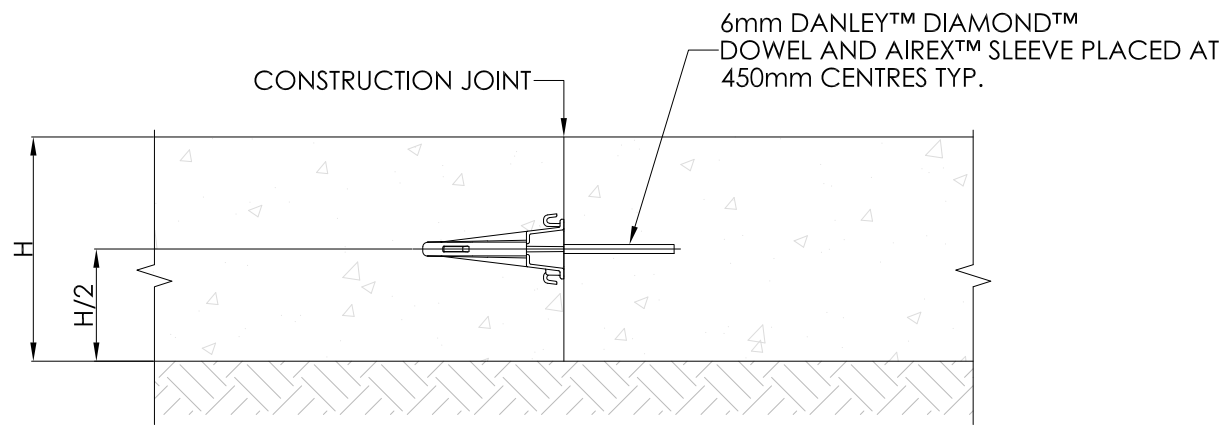

PLATE DOWEL JOINT (P.D.J.)
SCALE: 1:5

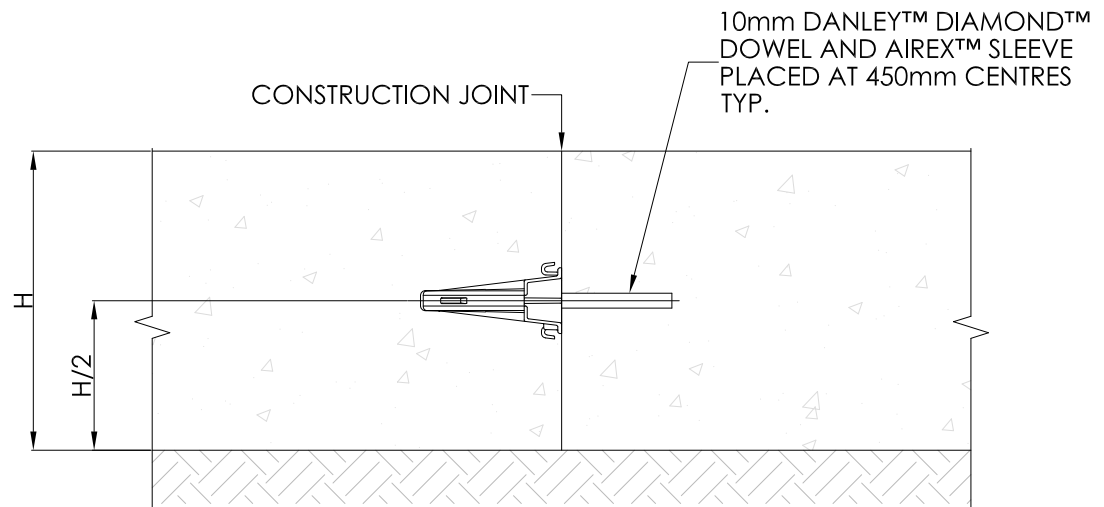

PLATE DOWEL JOINT (P.D.J.)
SCALE: 1:5

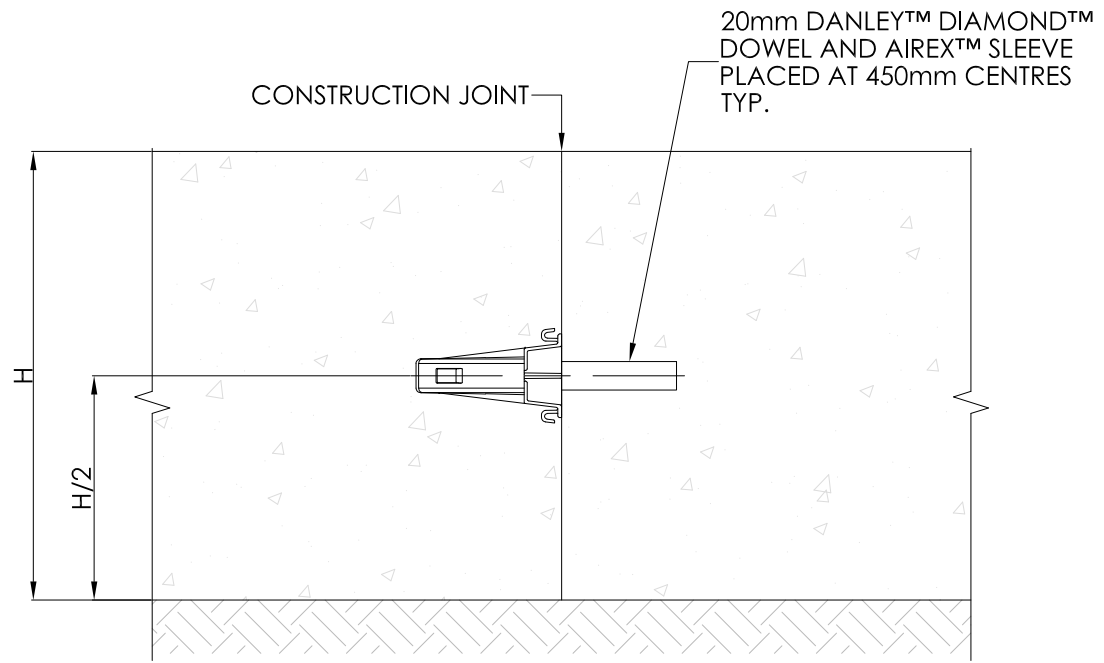

PLATE DOWEL JOINT (P.D.J.)
SCALE: 1:5

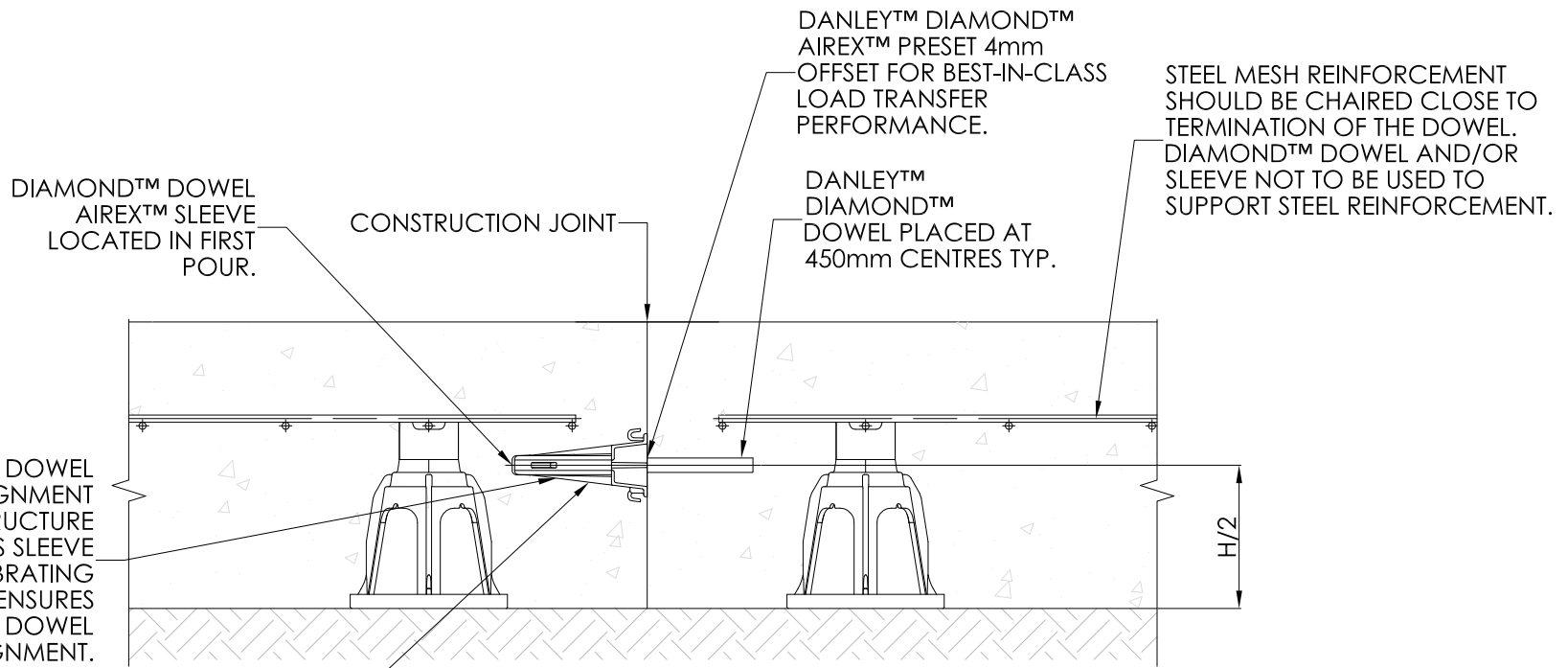

PLATE DOWEL JOINT (P.D.J.)
SCALE: 1:5

NOTE FOR SPECIFIER: NOT TO BE INCLUDED IN CONSTRUCTION DRAWINGS
THIS IS A TYPICAL MESH REINFORCEMENT PLACEMENT DETAIL. ALTERNATE DESIGN METHODS INCORPORATING DIFFERING MESH PLACEMENT CAN BE USED IN PLACE OF THIS DETAIL AT THE DISCRETION OF THE ENGINEER. FOR FURTHER INFORMATION REGARDING ALTERNATIVE ACCEPTABLE JOINT DETAILS, PLEASE CONTACT YOUR LOCAL DANLEY REPRESENTATIVE.

GENERAL NOTES:
DIAMOND™ DOWEL AIREX™ DANLEY™ DIAMOND™ TAPERED PLATE DOWEL (GRADE 300, AS/NZS 3679) PROVIDING BILATERAL MOVEMENT AT A 1:1 RATIO TO THE JOINT OPENING AND WITH 10mm OF EXPANSION CAPABILITY FOR EXPANSION JOINT APPLICATIONS. AVAILABLE IN 6mm & 10mm IN BLACK, GALV. OR STAINLESS. AVAILABLE IN 20mm IN GALV.

21 STEEL PLACE, MORNINGSID, QLD, 4170.
A DIVISION OF ITW AUSTRALIA PTY. LTD.
TEL: 1300 DANLEY (1300 326 539) FAX: (07) 3899 1733
EML: sales@danley.com.au
WEB: www.danley.com.au

DESCRIPTION: DIAMOND™ DOWEL AIREX™ SECTIONAL VIEWS			
SIGNED:	DRAWN: GMASON	VERIFIED: DMANTLE	APPROVED: AMCFARLAND
DATE:	03/04/23	15/05/23	16/05/23
CAD FILE: DAN-DWG-009 - Diamond™ Dowel AirEx™ Sectional Views			
DRAWING NO: DAN-DWG-009		SCALE: 1:5	REVISION: 2
SHEET: 1 OF 2		SIZE: A3	

DO NOT SCALE THIS DRAWING.